

MAGNATEX[®]

Pumps, Inc.

USER MANUAL

MFRP

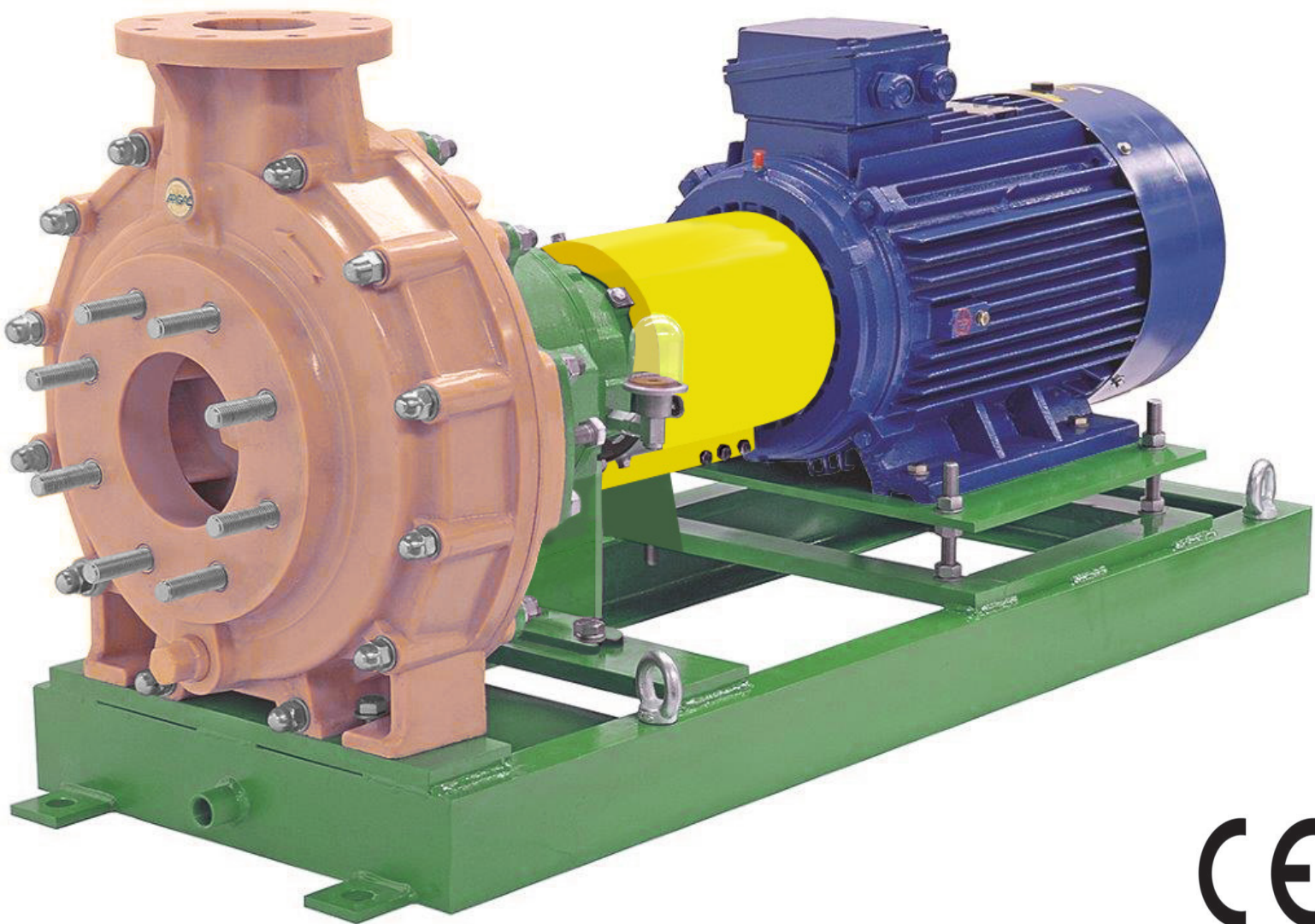

DEALER:

Magnatex Pumps, Inc.
3375 West 12th Street, Houston, TX, 77008
Toll Free: 866.MAG.PUMP
Phone: 713.972.8666
Fax: 713.972.8665

for Maintenance

date of commissioning:

position / system reference:

service:

INDEX:

3—IDENTIFICATION CODE

4—SECTION VIEW - size G3

5—*LEGEND - size G3*

6—SECTION VIEW - size G4

7—*LEGEND - size G4*

8—*MECHANICAL SEAL: BF*

8—*MECHANICAL SEAL: TR*

8—*MECHANICAL SEAL: MTR*

9—*LEGEND INTERNAL MECHANICAL SEAL TYPE BF..*

9—*LEGEND EXTERNAL MECHANICAL SEAL TYPE TR..*

9—*LEGEND DOUBLE MECHANICAL SEAL MTR..*

10—GENERAL NOTES

11—OPERATING PRINCIPLES OF THE PUMP

11—*HYDRAULICALLY*

11—*MECHANICALLY*

11—*THE MECHANICAL SEAL*

11—MOTOR

11—*ELECTRICAL CONNECTIONS*

11—*PROTECTION LEVEL*

12— DIRECTIONS FOR USE

12—*TRANSPORT*

12—*STORAGE INSTRUCTIONS*

12—*INSTALLATION INSTRUCTIONS*

13—*PRESSURE SWITCH TO PREVENT DRY RUNNING*

14—*START-UP*

14—*USE*

14—*SHUTDOWN*

14—*MAINTENANCE*

15—*INSPECTION*

15—SAFETY RISKS

15—INSTALLATION AND START-UP PERSONNEL

15—MAINTENANCE AND OPERATIONAL PERSONNEL

16—PERSONNEL RESPONSIBLE FOR REPAIRS

16—WASTE DISPOSAL

16—RECOMMENDATIONS

16—*DISASSEMBLING*

17—*IMPROPER USE*

17— OPERATING FAULTS AND POSSIBLE CAUSES

17— LUBRICATION

18— INSTRUCTIONS FOR FILLING LUBRICATING OIL

19— TECHNICAL DATA

ADDENDA: User manual standard elastic coupling

IDENTIFICATION CODE

PUMP DATA							MOTOR DATA			
size	model	version	O-ring material	Ø impeller	mechanical seal		baseplate	rpm	standard	power
G3	<input type="checkbox"/> 3x2x8	<input type="checkbox"/> V1G resina vinilestere standard	<input type="checkbox"/> V FPM	_____mm	<input type="checkbox"/> TR5		<input type="checkbox"/> 245	<input type="checkbox"/> 1450	<input type="checkbox"/> E IEC	_____kW
	<input type="checkbox"/> 3x2x10	<input type="checkbox"/> V1A miscela resina vinilestere	<input type="checkbox"/> E EPDM		<input type="checkbox"/> TR8		singola esterna	<input type="checkbox"/> 252	<input type="checkbox"/> 2900	
	<input type="checkbox"/> 4x3x8	<input type="checkbox"/> V1C miscela resina vinilestere	<input type="checkbox"/> F FEP		<input type="checkbox"/> TC8				<input type="checkbox"/> 258	<input type="checkbox"/> 1750
	<input type="checkbox"/> 4x3x10	<input type="checkbox"/> V1F miscela resina vinilestere	<input type="checkbox"/> K FFKM		<input type="checkbox"/> BF8	singola interna	<input type="checkbox"/> 264	<input type="checkbox"/> 3500		
	<input type="checkbox"/> 6x4x10	<input type="checkbox"/> E1S resina epossidica			<input type="checkbox"/> MTR5	doppia flussata	<input type="checkbox"/> 268			
	<input type="checkbox"/> 6x4x13				<input type="checkbox"/> MTR6		<input type="checkbox"/> 280			
G4	<input type="checkbox"/> 8x6x13			<input type="checkbox"/> MTC8			<input type="checkbox"/> 368			
	<input type="checkbox"/> 10x8x15						<input type="checkbox"/> 380			
						<input type="checkbox"/> 398				

Year of manufacture	part number
_____	_____

Each pump is supplied with the serial and model abbreviation and the serial number on the rating plate, which is riveted onto the support side. Check these data upon receiving the goods. Any discrepancy between the order and the delivery must be communicated immediately.

In order to be able to trace data and information, the abbreviation, model and serial number of the pump must be quoted in all correspondence.

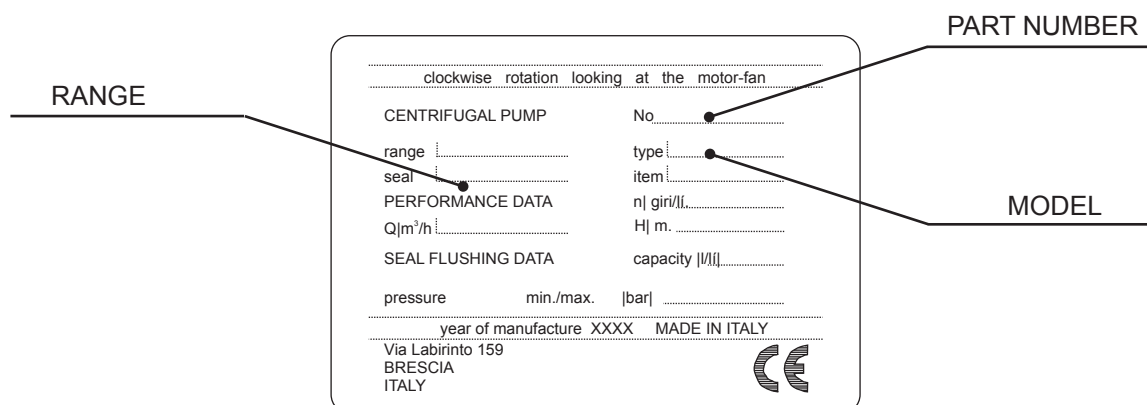

SECTION VIEW - size G3

VEDI TENUTE MECCANICHE
SEE MECHANICAL SEAL

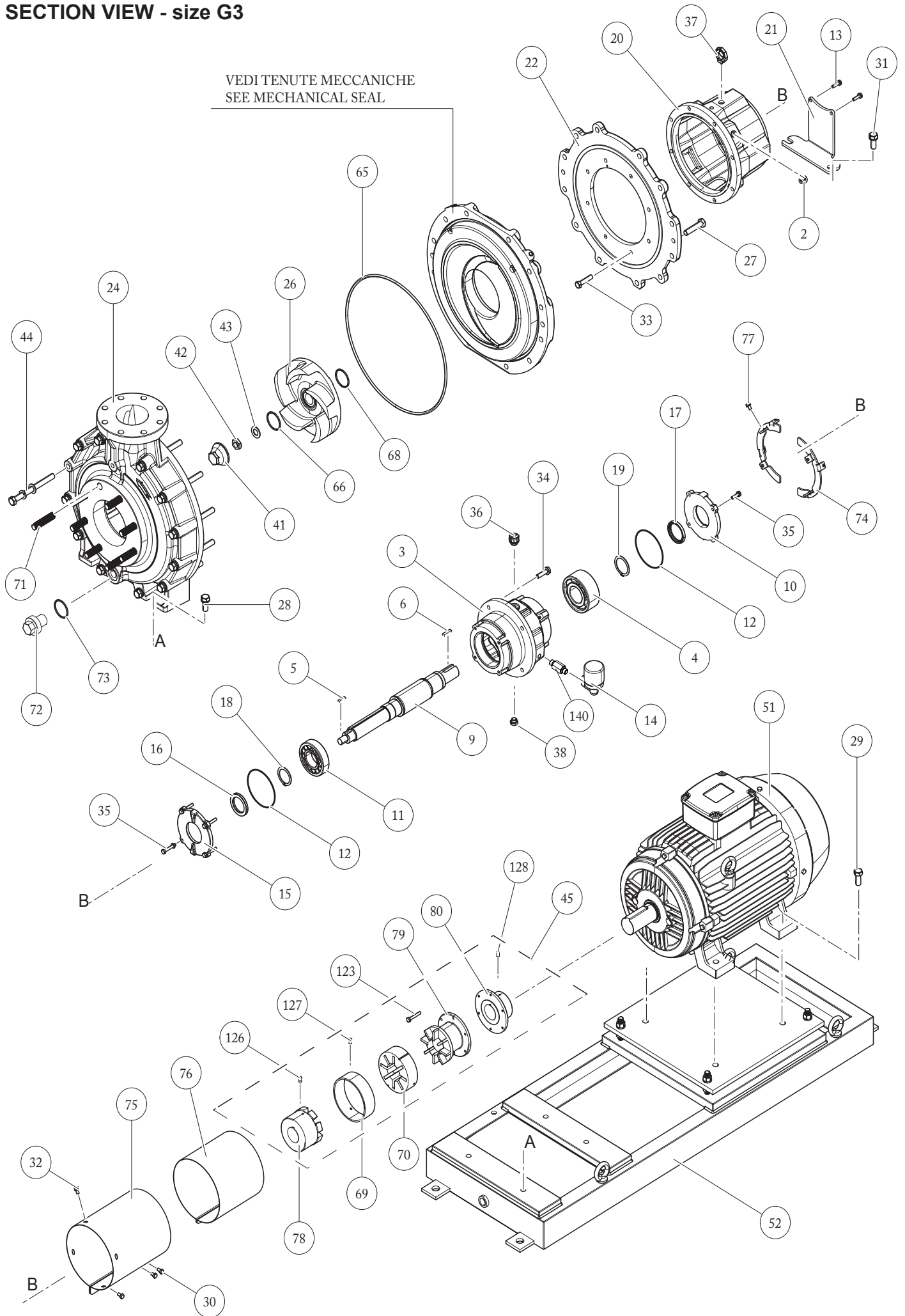

LEGEND - size G3

pos.	ref	Part name	Q.ty	Disassembling steps sequence (A1,...,A10,B1,...,B10,C1....)										Spare parts stock			
				1	2	3	4	5	6	7	8	9	10	start up	2 years	5 years	
2	939	Plug	1	A													
3	807.1	Bearing flange	1								B						
4	320.1	Bearing (motor side)	1							B					1	1	
5	940.1	Feather key (impeller)	1														
6	940.2	Feather key (motor)	1														
9	210	Shaft	1								B						
10	360.1	Bearing cover (motor side)	1			B											
11	320.2	Bearing (pump side)	1							B					1	1	
12	412.5	O-ring bearing cover	2				B								1	1	
13	910.11	FASTENERS Base support / support	1		A												
14	643	Constant level oiler	1	A													1
15	360.2	Bearing cover (pump side)	1			B											
16	421.1	MIM	1				B								1	1	
17	421.2	MIM	1				B								1	1	
18	932.1	Seeger ring	1					B									
19	932.2	Seeger ring	1					B									
20	331	Bracket	1														
21	183	Base support	1			A											
22	155	Rear flange	1									A					
24	102	Volute casing	1		A												
26	230	Impeller	1						A						1	1	
27	910.6	Removing plate screws	2														
28	910.1	FASTENERS volute casing / baseplate	1	A													
29	910.2	FASTENERS motor / motor thickness	1	A													
30	910.12	FASTENERS coupling cover	1	A													
31	910.4	FASTENERS Base support / baseplate	1	A													1
32	910.14	FASTENERS Coupling cover flange /Coupling cover	1	A													
33	910.9	FASTENERS rear flange / support	1														
34	910.10	FASTENERS support / bearing cover	1	B													
35	910.7	FASTENERS bearing flange / bearing cover	1		B												
36	638.1	Oil hole cup	1	A													1
37	918	Eyebolt	1	A													
38	638.2	Oil drain plug	1	A													1
41	260	Ogive	1			A									1	1	
42	920	Nut impeller	1				A										1
43	925	Washer	1					A									1
44	910.5	FASTENERS volute casing / rear flange	1	A													
45	840	Coupling (complete)	1														
51	800	Motor	1		A												
52	891	Baseplate	1														
65	412.1	O-ring volute casing / intermediate disc	1			A								1	1	1	
66	412.2	O-ring impeller (pump side)	1							A				1	1	1	
68	412.3	O-ring impeller (motor side)	1							A				1	1	1	
69	850	Ring (elastic insert)	1				A							1	1	1	
70	848	Elastic insert	1					A						1	1	1	
71	905	Tie rods		A													1
72	638.3	Drain plug	1	A													1
73	412.4	O-ring drain plug	1		A										1	1	
74	875.1	Coupling cover flange	2			A											
75	875.2	Coupling cover (fixed)	1		A												
76	875.3	Coupling cover	1		A												
77	910.15	FASTENERS coupling cover flange/coupling cover	1		A												
78	842	Semi coupling(pump side)	1							A							1
79	862	Spacer	1							A							1
80	841	Semi coupling (motor side)	1							A							1
123	901	FASTENERS coupling						A									
126	904.1	Grub screw semi coupling(pump side)	1			A											
127	904.2	Grub screw ring (elastic insert)	2			A											
128	904.3	Grub screw coupling (motor side)	1			A											
140	910.30	Oiler kit connection	1	A													1

SECTION VIEW - size G4

VEDI TENUTE MECCANICHE
SEE MECHANICAL SEAL

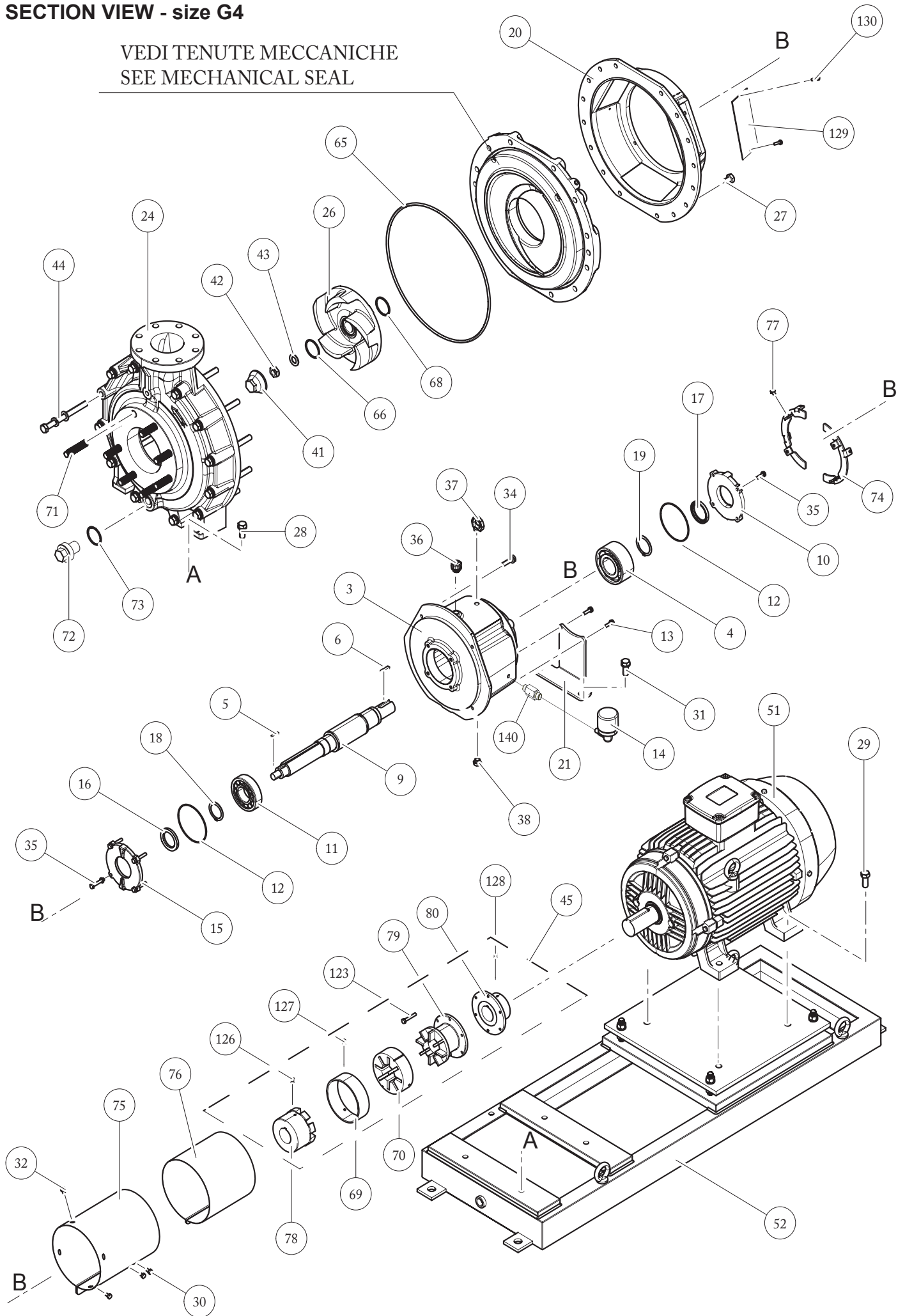

LEGEND - size G4

pos.	ref	Part name	Q.ty	Disassembling steps sequence (A1,....,A10,B1,....,B10,C1....)										Spare parts stock			
				1	2	3	4	5	6	7	8	9	10	start up	2 years	5 years	
3	807.1	Bearing flange	1									B					
4	320.1	Bearing (motor side)	1							B						1	1
5	940.1	Feather key (impeller)	1														
6	940.2	Feather key (motor)	1														
9	210	Shaft	1									B					
10	360.1	Bearing cover (motor side)	1			B											
11	320.2	Bearing (pump side)	1							B						1	1
12	412.5	O-ring bearing cover	2				B									1	1
13	910.11	FASTENERS Base bracket / braket	1		A												
14	643	Constant level oiler	1	A													1
15	360.2	Bearing cover (pump side)	1			B											
16	421.1	MIM	1				B									1	1
17	421.2	MIM	1				B									1	1
18	932.1	Seeger ring	1					B									
19	932.2	bearing flangeSeeger ring	1					B									
20	331	Bracket	1														
21	183	Base support	1			A											
24	102	Volute casing	1		A												
26	230	Impeller	1						A							1	1
27	910.6	Removing plate screws	2														
28	910.1	FASTENERS volute casing / baseplate	1	A													
29	910.2	FASTENERS motor / motor thickness	1	A													
30	910.12	FASTENERS coupling cover	1	A													
31	910.4	FASTENERS Base support / baseplate	1	A													1
32	910.14	FASTENERS Coupling cover flange /Coupling cover	1	A													
34	910.10	FASTENERS support / bearing cover	1	B													
35	910.7	FASTENERS bearing flange / bearing cover	1		B												
36	638.1	Oil hole cup	1	A													1
37	918	Eyebolt	1	A													
38	638.2	Oil drain plug	1	A													1
41	260	Ogive	1			A										1	1
42	920	Nut impeller	1				A										1
43	925	Washer	1					A									1
44	910.5	FASTENERS volute casing / rear flange	1	A													
45	840	Coupling (complete)	1														
51	800	Motor	1		A												
52	891	Baseplate	1														
65	412.1	O-ring volute casing / intermediate disc	1			A										1	1
66	412.2	O-ring impeller (pump side)	1							A						1	1
68	412.3	O-ring impeller (motor side)	1							A						1	1
69	850	Ring (elastic insert)	1				A									1	1
70	848	Elastic insert	1					A								1	1
71	905	Tie rods		A													1
72	638.3	Drain plug	1	A													1
73	412.4	O-ring drain plug	1		A											1	1
74	875.1	Coupling cover flange	2			A											
75	875.2	Coupling cover (fixed)	1		A												
76	875.3	Coupling cover	1		A												
77	910.15	FASTENERS coupling cover flange/coupling cover	1		A												
78	842	Semi coupling(pump side)	1							A							1
79	862	Spacer	1						A								1
80	841	Semi coupling (motor side)	1							A							1
123	901	FASTENERS coupling						A									
126	904.1	Grub screw semi coupling(pump side)	1			A											
127	904.2	Grub screw ring (elastic insert)	2			A											
128	904.3	Grub screw coupling (motor side)	1			A											
129	135	Protection	2		A												
130	910.20	FASTENERS Protection / bracket	2	A													
140	910.30	Oiler kit connection	1	A													1

MECHANICAL SEAL: BF

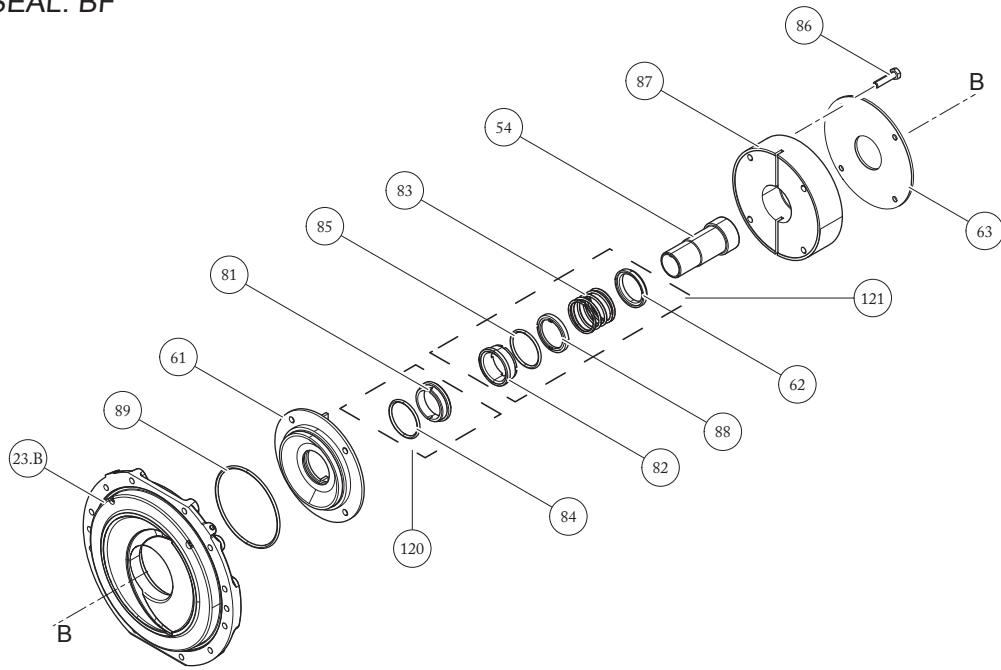

MECHANICAL SEAL: TR

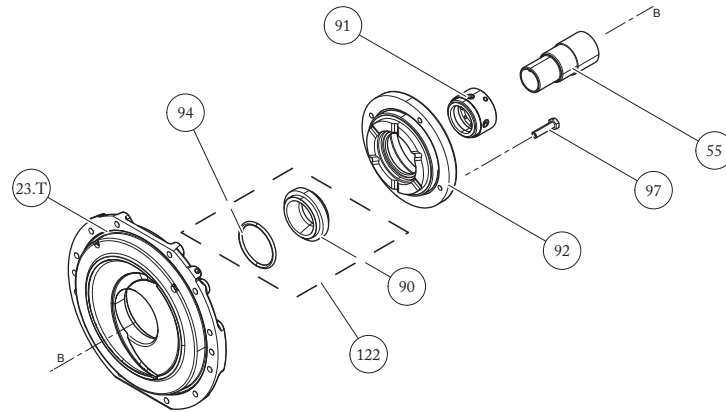

MECHANICAL SEAL: MTR

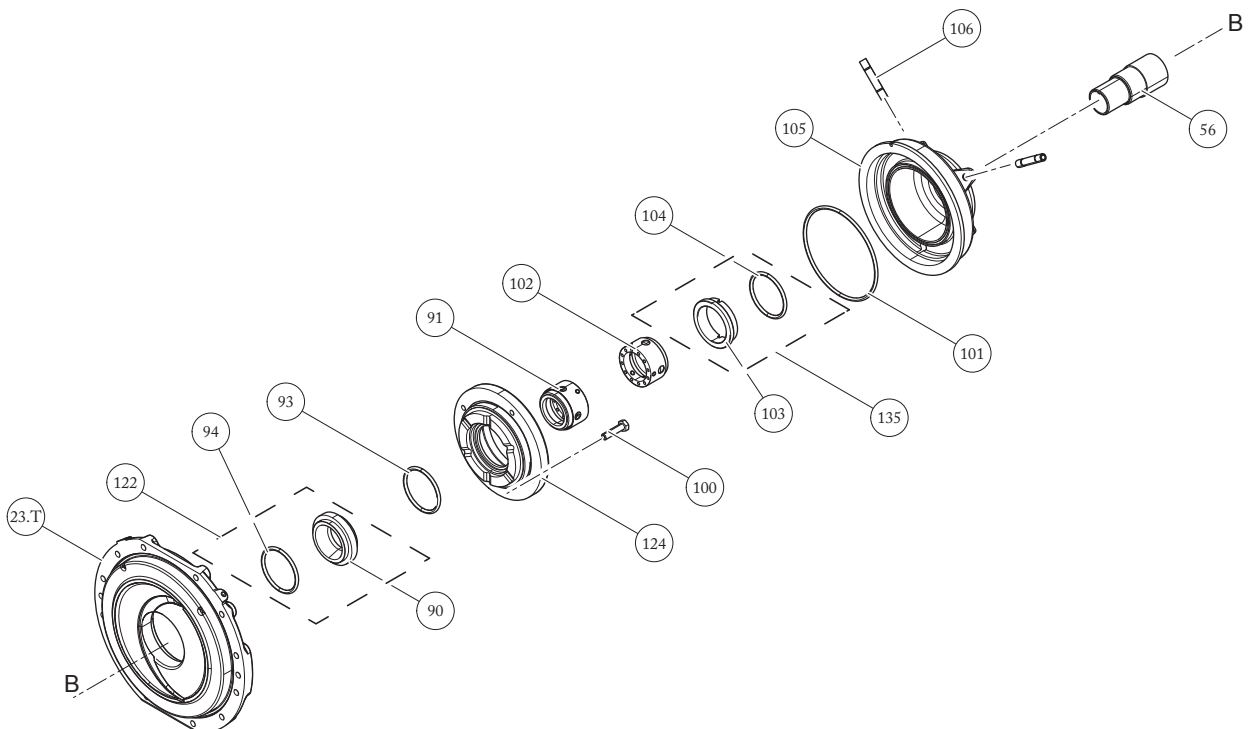

LEGEND INTERNAL MECHANICAL SEAL TYPE BF..

pos.	ref	Part name	Q.ty	Disassembling steps sequence (A1,...,A10,B1,...,B10,C1....)										Spare parts stock			
				1	2	3	4	5	6	7	8	9	10	start up	2 anni	5 anni	
23.B	134.1	Intermediate disc	1														
54	524.1	Shaft sleeve (BF)	1												1	1	1
61	135.1	Diaphragm	1														1
62	488	Lock ring	1				C										1
63	360	Locking counter-plate	1		C												1
81	472.1	Rotating seal	1											1	1	1	
82	475.1	Fixed seal	1					C						1	1	1	
83	477	Spring	1				C										1
84	412.6	O-ring rotating seal	1											1	1	1	
85	412.7	O-ring fixed seal	1						C					1	1	1	
86	910.16	FASTENERS counter-plate / spring spacer	1	C													
87	478	Spring spacer	1			C											1
88	476	Stationary seal locking ring	1					C									1
89	412.8	O-ring diaphragm / intermediate disc	1										C	1	1	1	
120		ROTATING SEAL COMPLETE															
121		FIXED SEAL COMPLETE															

LEGEND EXTERNAL MECHANICAL SEAL TYPE TR..

pos.	ref	Part name	Q.ty	Disassembling steps sequence (A1,...,A10,B1,...,B10,C1....)										Spare parts stock			
				1	2	3	4	5	6	7	8	9	10	start up	2 anni	5 anni	
23.T	134.2	Intermediate disc	1														
55	524.2	Shaft sleeve (TR)	1												1	1	1
90	475.2	Fixed seal	1				C							1	1	1	
91	472.2	Rotating seal	1	C										1	1	1	
92	135.2	Diaphragm TR	1		C												1
93	412.7	O-ring	1														
94	412.8	O-ring fixed seal	1				C							1	1	1	
97	910.17	FASTENERS Diaphragm	1	C													
122		FIXED SEAL COMPLETE															

LEGEND DOUBLE MECHANICAL SEAL MTR..

pos.	ref	Part name	Q.ty	Disassembling steps sequence (A1,...,A10,B1,...,B10,C1....)										Spare parts stock			
				1	2	3	4	5	6	7	8	9	10	start up	2 anni	5 anni	
23.T	134.2	Intermediate disc	1														
56	524.3	Shaft sleeve(MTR)	1												1	1	1
90	475.2	Fixed seal (pump side)	1										C	1	1	1	
91	472.2	Rotating seal (pump side)	1					C						1	1	1	
93	412.7	O-ring fixed seal / diaphragm	1										C				
94	412.8	O-ring fixed seal	1										C	1	1	1	
100	910.19	FASTENERS flushing chamber	1														
101	412.9	O-ring flushing chamber	1				C							1	1	1	
102	472.3	Rotating seal (motor side)	1		C									1	1	1	
103	475.3	Fixed seal (motor side)	1					C						1	1	1	
104	412.10	O-ring fixed seal	1					C						1	1	1	
105	471	Flushing chamber	1			C											1
106	910.18	Flushing piping	2	C													1
122		FIXED SEAL COMPLETE (pump side)															
135		FIXED SEAL COMPLETE (motor side)															
124	605.3	Diaphragm MTR	1						C								1

GENERAL NOTES

“ZGS” pumps are designed and built for the transfer of liquid chemical products having a specific weight, viscosity, temperature and stability of state appropriate for use with centrifugal pumps in a fixed installation, from a tank at a lower level to a tank or a pipe to a higher level. The characteristics of the liquid (pressure, temperature, chemical reactivity, specific weight, viscosity, vapour tension) and the environmental conditions must be compatible with the characteristics of the pump and are defined upon ordering. Impeller and static casings, in contact with the liquid, are constructed from thermosetting resins; other parts in high chemical-resistant materials.

The pump's performance (capacity, head, rpm) is defined upon ordering and specified on the identification plate.

“ZGS” series pumps are manufactured in compliance with ANSI/ASME B73.1 standards. They are of the centrifugal, horizontal, single-stage type, with self-supporting shaft. ZGS pumps are coupled to a non-synchronous electric motor by means of flexible coupling and spacer; with axial inlet and radial outlet for connection to the hydraulic system. These pumps are of the foot-mounted type for fixing onto base-plate in compliance with ASME B73.1.

“ZGS” pumps are not self priming.

“ZGS” pumps cannot run dry.

The liquid being pumped may contain a maximum 5% of solid non-abrasive particles not greater than 0,1 mm in size. The presence of fibrous, adhesive or abrasive bodies is not allowed. The maximum allowed size for bodies occasionally present is 0,5 mm.

Clockwise rotation seen from the motor side.

Make sure that the chemical and physical characteristics of the liquid have been carefully evaluated for pump suitability.

The specific weight which can be pumped at a temperature of 25°C (both of the liquid and the ambient) depends upon the diameter of the impeller (shown on the identification plate) and the installed motor power (shown on the motor identification plate) and has to be defined upon ordering.

The level of kinematic viscosity must not exceed 40 cSt so as not to significantly modify the pump's performance. Higher values up to a maximum of 120 cSt are possible provided that the pump is equipped with suitable impeller and motor to be defined upon ordering.

The maximum continuous working temperature referred to water depends on the choice of materials (specified on the identification plate):

80 °C	execution V1G
80 °C	execution V1A
80 °C	execution V1C
80 °C	execution V1F
110°C	execution E1S

modifications may occur depending upon the operating pressure value.

The ambient temperature interval is related to the choice of materials (specified on the identification plate):

The maximum pressure the pump may be subjected to is 1.5 times the head value developed with the outlet closed.

The vapour pressure value of the liquid to be pumped must exceed (by at least 1m w.c) to the difference between the absolute total head (suction side pressure added to the positive suction head, or subtracted by the suction lift) and the pressure drops in the suction side piping (including the inlet NPSHr drops shown on the specific tables).

In case of double mechanical seal, the value of the pressure in the seal chamber must be equal to half value of the operating pressure of the pump.

In case of double mechanical seal, the flushing liquid must be clean and must not lead to violent chemical reactions on contact with the liquid being pumped.

The pump shaft is supported by rolling bearings packed with grease (to be periodically recharged).

The pump does not include any non return valve nor any liquid flow control or motor stop device.

The coupling guard must be fitted before starting up the pump.

OPERATING PRINCIPLES OF THE PUMP

HYDRAULICALLY alike to all centrifugal pumps, it is equipped with a blade-type impeller rotating within a fixed housing. It has a radial outlet (facing the upper part of the pump, with an internal deflector) and, by creating a depression in the center, it allows the liquid to flow from the central suction side. Then, flowing through the impeller's blades the fluid acquires energy and is conveyed towards the outlet.

MECHANICALLY, the static stress caused by the piping is borne by the pump body. Directly the pump shaft causes the impeller to rotate and is driven by rolling bearings that transfer all the mechanical impeller loads onto the support. The pump is connected to the electric motor (IEC, B3 frame, to be fixed onto a common base) by means of a flexible coupling and spacer. A guard (non-hermetically sealed) prevents unauthorised access. The spacer allows worn components (pump rotor) to be removed without having to disconnect the piping and remove the motor.

THE MECHANICAL SEAL, placed at the point where the shaft enters the pump body to drive the impeller, is made up of two main sections: a fixed section inserted in the pump body and a rotating section integral with the shaft. The tight contact between these two parts guarantees a seal against leakage whether the pump is rotating or not. The rubbing action that occurs between these two parts when the pump is operating generates heat by friction; this heat is absorbed by the liquid being pumped in the case of single mechanical seal and by the cooling liquid (generally water) in the case of double seal. The presence of the thin layer of liquid between the sealing surfaces, as well as its cooling action, is indispensable for the life of the seal.

MOTOR

ELECTRICAL CONNECTIONS

The electrical connection to the motor terminal determines the direction of rotation of the motor and can be verified by looking at the cooling fan at the rear of the motor (for the Argal pump this has to rotate clockwise looking at the front end).

With single phase motors the direction of rotation may be reversed by changing the position of the connection plates.

With three-phase motors the direction of rotation may be changed by swapping any two of the three conductors independently of the type of connection to the windings:

Star/Delta starting is used when the motor power is above 7.5 kW (10 HP) only in case of frequent starts and short running times, but always when the motor power is above 15 kW (20 HP). All this is also to safeguard the structure of the pump.

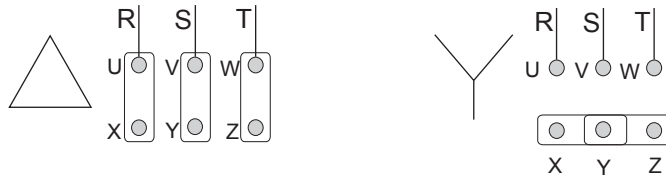

PROTECTION LEVEL

The initials IP are followed by two numbers :

The first number indicates the level of protection against penetration of solid objects, The second number indicates the protection against the penetration of liquids.

According to the IP protection indicated on the identification plate of the motor and to the environmental conditions, arrange for opportune extra protections allowing in any case correct ventilation and rapid drainage of rainwater.

DIRECTIONS FOR USE

TRANSPORT

- cover the hydraulic connections
- when lifting the unit do not exert force on the plastic fittings
- lay the pump on its base or fixing plate during transport
- if the road is particularly rough, protect the pump by means of adequate shock absorbing supports
- bumps and shocks may damage important working parts vital for safety and functionality of the machine

STORAGE INSTRUCTIONS

- When is necessari to store the pump bfore installation don't remove it from the original packaged. The packaged pump must be stored lifted from ground level, the ambient must be close, clean and dry.
- If at the receipt of the pump package seems damaged is necessary to free the pump in order to check its integrity and to store a new package
- The place where the pump is stored must be closed with an ambient temperature not lower than -5°C and not higher than 40°C , the air humidity rate not higher than 80%, the package pump mustn't received shock, vibrations and loads rising above.
- If the storing period is higher than 6 months, bfore installation check the condition of the grease in the support, eventually provide to restore it.

INSTALLATION INSTRUCTIONS

- clean the plant before connecting the pump
- make sure that no foreign bodies are left in the pump. Remove safety caps on the hydraulic connections.

follow the instructions indicated in the following diagram:

- 1) Suction head adapts to delivery rate in order to prevent winage
- 2) YES: expansion joint (indispensable with long piping or hot liquids) and/or vibration damping system at inlet and outlet; anchor system near the pump
- 03) YES: connection point for pressure gauge or safety pressure switch
- 04) YES: non-return valve (particularly with long vertical or horizontal pipe runs; mandatory with pumps in parallel)
- 05) YES: flow control valve on the discharge side
- 06) Maximum fluid speed on the discharge side: 3.5 m/sec
- 07) NO: bends (or other fittings) close to the pump (both at inlet and outlet)
- 08) Auxiliary piping for double mechanical seal (only for M type seals):
- 09) pressure reducer
- 10) inlet filter
- 11) inlet shut-off valve
- 12) delivery hand control valve
- 13) pressure gauge for checking seal chamber pressure
- 14) YES: drain channel around the base plate
- 15) The pump must be installed using all of the fixing holes provided; the fixing points must be kept at the same level
- 16) YES: pipe drain (perfectly airtight); drain valve must be closed when the system is working
- 17) YES: firmly fix all piping by suitable brackets, close to the pump
- 18) YES: drain collecting sump (leak proof)
- 19) Maximum fluid speed on suction side: 2.5 m/sec
- 20) NO: air pockets. The circuit must be linear and short
- 21) Incline the piping towards the pump
- 22) YES: shut off gate valve (one is also fitted near the pump in case of long piping)
- 23) YES: filtering sector (5÷10 mm mesh screen)

- anchor the pump to an adequate base plate having a mass at least 5 times that of the pump
- do not use anti-vibration mounts to fix the pump
- anti-vibration joints are recommended on the pipe connections
- manually verify that all rotating parts are free to turn without abnormal friction by turning the motor cooling fan
- make sure that the power supply is compatible with the data shown on the pump motor identification plate
- connect the motor to the power supply via a magnetic/thermal control switch
- ensure that star-delta starting is implemented for motors whose power is more than 15kW
- install emergency stop devices to switch off the pump in case of low liquid level (floating, magnetic, electronic, pressure-sensitive)
- ambient temperature as a function of the physical-chemical characteristics of the liquid to be pumped and in any

case not greater or lower than the interval indicated in the GENERAL HINTS

- other environmental conditions in accordance with the IP protection of the motor
- install a drainage pit to collect any liquid overflow from the base drainage channel due to normal maintenance work
- leave enough free space around the pump for a person to move
- leave free space above the pump for lifting operations
- highlight the presence of aggressive liquids with coloured tags following the local safety regulations
- do not install the pump (made in thermosetting material) in close proximity to heating apparatus
- do not install the pump in areas subject to solid or liquid matter falling
- do not install the pump in an explosive atmosphere unless the motor and its coupling have been adequately pre-arranged
- do not install the pump in close proximity to workplaces or crowded areas
- install extra protection guards for the pump or persons as the need arises
- install a spare equivalent pump in parallel

CAUTION: final alignment of the pump and driver through the flexible coupling must be done after the pump installation and before the pump start. During transit and subsequent handling any factory alignment may be disturbed. The pump must be fixed to the base of support and to the foundation. To access the elastic coupling remove the protections ref. 75 and 76. For the assembly and alignment instructions you refer to the instructions of the manufacturer of the coupling (attached the manual of standard elastic coupling).

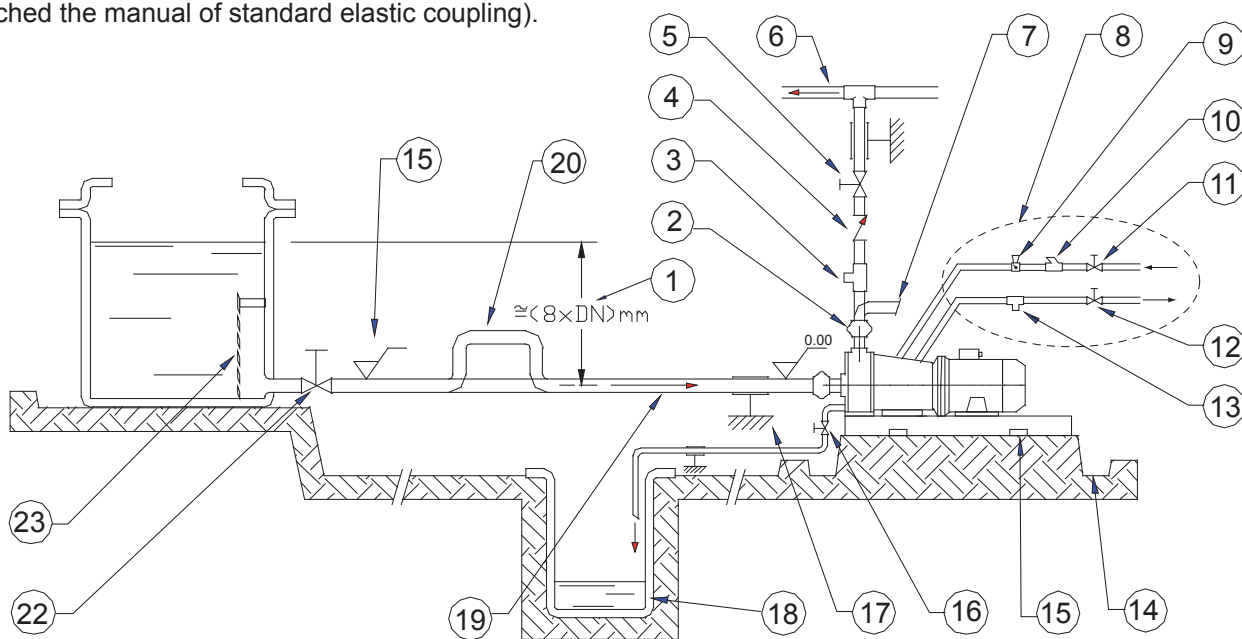

MAX TORQUE FROM EQUATION SETS AT 20°C [Nm]	
25	2" / 3"
25	4"
33	6"
64	8"

PRESSURE SWITCH TO PREVENT DRY RUNNING

The principal cause of pump malfunctions is dry-running (being it caused by improper use or cavitation). It is therefore advisable to install a simple device that will stop the pump motor when the pressure falls below a preset level. This is justified by the fact that such a condition is normally caused to an inadequate flooding of the impeller due to various causes: absence of liquid, suction valves closed at start-up, cavitation, clogged channels, dirty filters, etc.....

The pressure switch (pressure gauge with electrical contacts) must be fitted on the discharge side of the pump at approximately 20cm from the outlet. This device needs furthermore:

- 1)) A fluid separator to transmit pressure to the instrument via a secondary fluid separated from the main one by a chemically resistant diaphragm.
- 2) Remote-control switch to energize the motor (controlled by a pushbutton or auxiliary relay) having the normally closed contact of the pressure switch in series with the latch circuit of said remote-control switch.

In order to obviate any pulsations of the pressure switch, it is necessary to set its setpoint to a pressure value equal to 65% of the working pressure. It is obvious that this device cannot be used to control working pressure.

On start-up the pressure switch contact must be by-passed for a sufficient time to allow pressure to build up in the system. In case of automatic start-up it is necessary to short circuit the latch with a timer for the pressure build-up time.

The system is not suitable for full capacity applications in which case it is advisable to install some control devices for the motor power absorbtion.

All of the above must be adapted to the local safety rules and in particular when the classification of the environment requires explosion-proof equipment.

START-UP

- verify that the instructions outlined in the INSTALLATION have been followed
- verify the correct direction of rotation (clockwise from the motor side) supplying the motor with short impulses
- ensure that the NPSH available is greater than that required by the pump (in particular for hot liquids, liquids with high vapour pressure, very long suction pipes or negative suction lift)
- close the discharge valve; completely cover the suction pipe and the pump.
- close the outlet valve. Start up the motor two or three times with short supplies of current in order to expel the air from the pump and the lubrication circuit between the guide shaft and bush.
- start the pump with the suction valve completely open and the outlet valve semi-closed.
- slowly adjust the flow by adjusting the outlet valve (never adjust the suction valve) and making sure that the motor absorption does not exceed the nominal power rating shown on the plate
- do not operate at the extremes of the operating curve: maximum head (discharge valve shut too tight) or maximum flow (total absence of loss and lift in discharge circuit).
- set the operating point for which the pump has been requested
- check that there are no unusual vibrations or noises due to inadequate fixing or cavitation
- avoid excessively short and/or frequent start-ups by adjusting the consent appliances

Motor power	kW	0,75÷5,5	7,5÷30	37÷110	132÷200	250÷315
Max. no. starts/hour	2-47 poli	20-40	10-20	6-12	2-4	1-2

- check that temperature, pressure and characteristics of liquid match order specifications

USE

- switch automatic control on
- do not activate valves whilst the pump is in operation
- risks of dangerous water hammer effects in case of sudden or improper valve actuation (only trained personnel should operate valves)
- completely empty and wash the pump before using a different liquid
- isolate or empty the pump if the crystallization temperature of the liquid is the same or lower than the ambient temperature
- stop the pump if the liquid temperature exceeds the maximum allowed temperature indicated in the general notes; if the increase is of approximately 20%, check internal parts
- close the valves in case of leaks
- wash with water only if compatible from the chemical point of view. As alternative use an appropriate solvent that will not generate dangerous exothermic reactions
- contact the liquid supplier for information on the appropriate fire precautions
- empty the pump in case of long periods of inactivity (in particular with liquids which would easily crystallize)

SHUTDOWN

- disconnect the motor
- before starting maintenance, turn off the suction and discharge valves

MAINTENANCE

- all these maintenance operations must be performed under the supervision of qualified personnel
- make periodic inspections (2 to 30 days depending on the type of liquid and the operating conditions) cleaning filtering sections
- make periodic inspections (1 to 6 months depending on the type of liquid and the operating conditions) on the rotating parts of the pump (pump rotor); clean or replace or lubricate as necessary (see RECOMMENDATIONS)
- make periodic inspections (3 to 5 months depending on the type of liquid and the operating conditions) on the functionality of the motor control system; efficiency must be guaranteed
- excessive current consumption could be an indication of impeller problems
- unusual vibrations could be due to unbalanced impeller (due to damage or presence of foreign material obstructing its blades)
- reduced pump performance could be due to an obstruction of the impeller or damages to the motor
- motor damages could be due to abnormal friction within the pump
- damaged parts must be replaced with new original parts
- the replacement of damaged parts must be carried out in a clean dry area

INSPECTION

Check:

- the pump shaft for cracks and excessive wear
- excessive wear of seal rings
- counterthrust bushing for cracks or excessive wear
- the impeller, volute and intermediate disk for abrasion and corrosion
- that the pressure balancing holes on the impeller blades are not blocked
- for lumps and clusters created by the pumped liquid (especially at the bottom of the rear chamber)

Replace broken, cracked or deformed parts.

Reopen all the blocked pipes and eliminate any chemical agglomeration.

Clean all surfaces before reassembly; in particular seal rings (risk of leakage or premature wear) and O-ring seats (risk of leakage).

SAFETY RISKS

WARNING! CHEMICAL HAZARD. The pumps are designed to pump different types of liquid and chemical. Follow the specific instructions to decontaminate during inspection or maintenance. §

WARNING! Safety risks for personnel mainly arise from improper use or accidental damages.

These risks may be of an electrical nature as far as the non-synchronous motor is concerned and may cause injury to hands if working on an open pump. Risks may also arise due to the nature of the liquids pumped. It is therefore of utmost importance to closely follow all the instructions contained in this manual so as to eliminate the causes that may lead to pump failure and the consequent leakage of liquid dangerous for both personnel and the environment.

Risks may also arise from improper maintenance or dismantling practices.

In any case five general rules are important:

A - all services must be carried out by specialised personnel or supervised by qualified personnel depending on the type of maintenance required

B - install protection guards against eventual liquid sprays (when the pump is not installed in remote areas) due to an accidental pipe rupture. Arrange for safety basins to collect possible leakage

C - when working on the pump always wear acid-proof protective clothing

D - arrange for proper conditions for suction and discharge valve closing during disassembly

E - make sure that the motor is completely disconnected during disassembly.

Proper design and building of the plants, with well positioned and well marked piping fitted with shut-off valves, adequate passages and work areas for maintenance and inspections are extremely important (since the pressure developed by the pump could give some kind of damage to the plant in case this one should be faulty made or wear and tear-damaged).

It must be stressed that the major cause of pump failures leading to a consequent need to intervene is due to the pump running dry in manually operated plants. This is generally due to:

- the suction valve being open at start-up or
- the suction tank being emptied without stopping

INSTALLATION AND START-UP PERSONNEL

Interventions allowed only to specialised personnel who may eventually delegate to others some operations depending on specific evaluations (technical capability required: specialisation in industrial plumbing or electric systems as needed).

MAINTENANCE AND OPERATIONAL PERSONNEL

Interventions allowed to general operators (after training on the correct use of the plant):

- pump starting and stopping
- opening and closing of valves with the pump at rest
- emptying and washing of the pump body via special valves and piping
- cleaning of filtering elements

Interventions allowed to qualified personnel (technical capacities required: general knowledge of the mechanical, electrical and chemical features of the plant being fed by the pump and of the pump itself):

- verification of environmental conditions
- verification of the condition of the liquid being pumped
- inspections of the control/stop devices of the pump

- inspections of the rotating parts of the pump
- trouble shooting

PERSONNEL RESPONSIBLE FOR REPAIRS

Interventions allowed to general operators under the supervision of qualified personnel:

- stopping of the pump
- closing of the valve
- emptying of pump body
- disconnection of piping from fittings
- removal of anchoring bolts
- washing with water or suitable solvent as needed
- transport (after removal of electrical connections by qualified personnel)

Interventions by qualified personnel (technical capacities required: general knowledge of machining operations, awareness of possible damage to parts due to abrasion or shocks during handling, know-how of required bolt and screw tightening required on different materials such as plastics and metals, use of precision measuring instruments):

- opening and closing of the pump body
- removal and replacement of rotating parts

WASTE DISPOSAL

Materials: separate plastic from metal parts. Dispose of by authorized companies.

RECOMMENDATIONS

DISASSEMBLING

all these maintenance operations must be performed under supervision of qualified personnel

cut off the power supply from the motor and disconnect the electrical wiring; pull the wires out from the terminal box and isolate their extremities accordingly

close discharge valves

use gloves, safety glasses and acid-proof overalls when disconnecting and washing the pump

disconnect the piping and leave enough time for the residual liquid to exit the pump body and atmospheric air to fill the empty volume

wash the pump before carrying out any maintenance work

do not scatter the liquid in the environment

lift the pump vertically avoiding to exert traction on the liner

before attempting to dismantle the pump ensure that its motor is disconnected and that it may not be started accidentally

now open the pump following the sequence indicated in the respective table of the LEGEND and following the suggestions outlined in the RECOMMENDATIONS section

ll threads are right handed

The impeller, once the pump rotor is disconnected, must be removed by blocking the opposite end of the shaft (removing the half coupling if necessary); unscrew the protection cap (ogive) and locking nut (right hand thread), then remove the impeller axially.

Follow the specific attached instructions when working on the mechanical seal.

Remove the shaft from its support (with the bearing on the motor side) by sliding it in direction of the coupling side; the bearing on the pump side must be in position before refitting the shaft (see Table 5: bearings and oil seal rings).

Replace the parts that was: broken, cracky, smelt.

Clean all surfaces before reassembly; in particular seal rings (risk of leakage or premature wear), O-RING seats (risk of leakage). bearings rings and seats of the support.

Shaft run-out on the impeller side must not exceed 30µm.

Check alignment and end play among the flexible components of the coupling after reassembling:

Max. radial deviation <0,5 mm; max. angular displacement <1°; end play: 2÷4 mm

Screw fastening torque		M4	M6	M8	M10	M12	M16	M20	M24
to be reduced by 25 % clamping plastic components	Nm	4	14	24	48	60	75	120	175

IMPROPER USE

The pump must not be used for purposes other than the transfer of liquids.

The pump cannot be used to generate isostatic or counter pressures.

The pump cannot be used to mix liquids generating an exothermal reaction

The pump must be installed vertically on a firm structure.

The pump must be installed on a suitable hydraulic plant with outlet connection to proper discharge pipe.

The plant must be able to shut off the liquid flow independently from the pump.

Handling of aggressive liquids requires specific technical knowledge

OPERATING FAULTS AND POSSIBLE CAUSES

The pump does not deliver:

01- wrong sense of rotation

02- suction piping is too long or has too many bends

03- not enough suction head on the pump

04- air intake from suction and secondary piping

05- pump or suction piping not completely flooded

06- impeller blades obstructed by impurities

07- non-return valve on the discharge pipe blocked

08- the geodetic head of the plant is greater than the maximum head developed by the pump

09- impeller blocked by a considerable layer of crystals or by melting due to dry running

The pump has reduced capacity or insufficient pressure: see 01, 02, 03, 04, 05, 06

10- the head required by the plant is greater than that expected

11- insufficient nominal diameter of suction piping, shut-off valve or other suction parts

12- insufficient geodetic suction head on the pump

13- damaged or worn impeller

14- viscosity of liquid greater than that expected

15- excessive quantities of air or gases in the liquid

16- bends, non-return valve or other parts close to the outlet

17- liquid (especially if hot) liable to change to gaseous state

The pump is overloaded: see 14

18- capacity is higher delivery than expected

19- the specific weight of the liquid is greater than expected

20- impurities inside the pump generate abnormal friction

21- the power supply voltage is not the one on the motor identification plate

The pump vibrates and is noisy: see 20

22- the pump is working at free capacity (zero head)

23- the pump or piping are not firmly fixed

24- damaged or dry central support bearings

25- wrong alignment of the flexible coupling

The pump shows signs of premature wear of internal parts: see 20

26- liquid is excessively abrasive

27- frequent recurrence of cavitation (see 02, 11, 15, 17)

28- high tendency of the liquid to crystallize or polymerize in stand-by

29- pump execution with materials not suitable for the liquid being pumped

30- operation at much reduced capacity

LUBRICATION

The pump is supplied without oil (bearing housing is empty); before starting pump fill with lubricating oil as per ISO 6743: Kinematics viscosity ref. to 50 °C (125°F): 2,8÷3,3 °E (≈ 20 cSt) - Operating conditions: temperature increment 40°C; max. temperature 100 °C; max. rpm 4000.

Business names: ESSO Teresso 68; SHELL Tellus T68; MOBIL DTE 68; BP Energol HLC 68; AGIP Blasias 68 (remark: 68 mm²/s at 40°C with gradation SAE 20).

Add oil in the bulb lubricator (100 cc) approximately every 300 hours of working.

Feed rate: 100cc/300hrs.

Completely drain and replace oil after 2000 operating hours.

Quantity required for the first filling: 2000 cc for G3 size / 7500 cc for G4 size.

INSTRUCTIONS FOR FILLING LUBRICATING OIL

1. Purpose:

Indicate the filling method of the bearing lubrication oil.

2. Applicability:

This statement refers to SATURN ZGS pumps.

3. Areas / corporations concerned:

REPAIRS - Customer.

4. Operating method:

Filling phases.

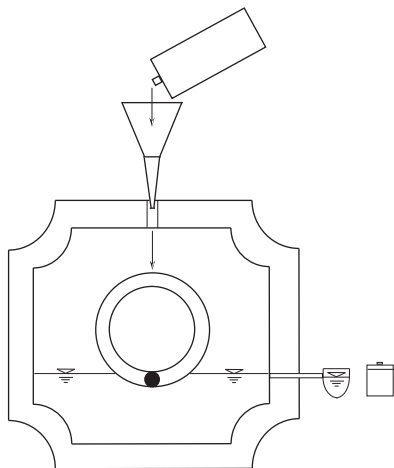

PHASE 1.

Fill with lubricant the appropriate oil hole at the top of the carrier.
During the filling phase keep open the ampoule.
The phase 1 is considered ended when the oil begins to overflow into the ampoule elbow.
This step is to be performed only during the starting of the pump.

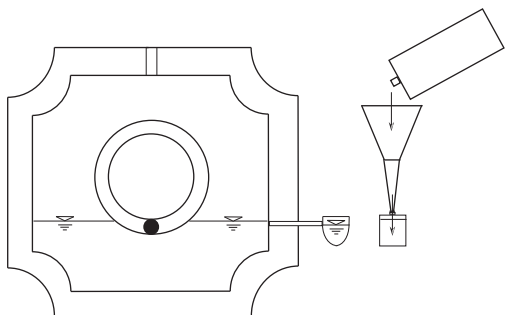

PHASE 2.

Unscrew the cup from its seat and fill it with lubricating oil through the upper spout.
Finally screw it on the ampoule.

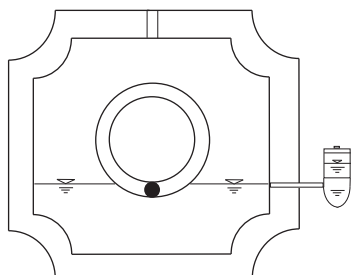

PHASE 3.

- Working conditions: the ampoule must be closed.
- Ordinary maintenance: repeat the step 2 only once the ampoule is being emptied completely of oil.

TECHNICAL DATA

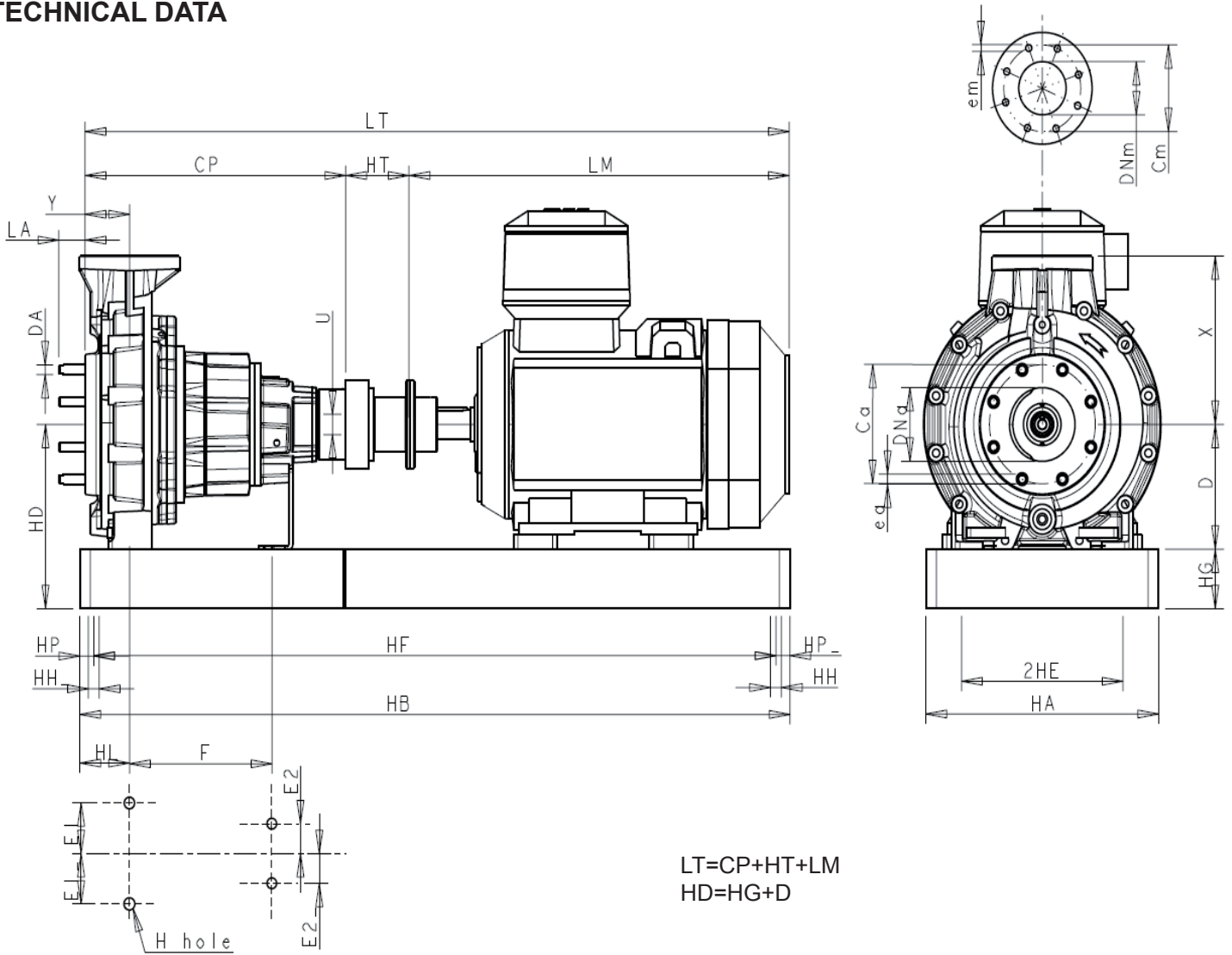

TAB. 1 PUMP ANSI/ASME B73.1

MODEL	CP	Y	D	X	F	E1	E2	H	U	LA	DA	weight (kg)
3 x 2 x 8	597	102	210	242	318	124	92	16	41,3	n.a.	n.a.	95
3 x 2 x 10	597	102	210	242	318	124	92	16	41,3	n.a.	n.a.	95
4 x 3 x 8	597	102	210	280	318	124	92	16	41,3	n.a.	n.a.	100
4 x 3 x 10	597	102	210	280	318	124	92	16	41,3	n.a.	n.a.	100
6 x 4 x 10	597	102	254	343	318	124	92	16	41,3	60	20	120
6 x 4 x 13	597	102	254	343	318	124	92	16	41,3	60	20	120
8 x 6 x 13	860	152	368	406	476	203	114,5	22	60,3	60	20	240
10 x 8 x 15	860	152	368	483	476	203	114,5	22	60,3	60	20	280

Dimension in mm

TAB. 2 CONNECTIONS - ANSI/ASME B16.5 class 150

MODEL	INLET					OUTLET				
	DNa	Ca	ea	n°	tipo	DNm	Cm	em	n°	tipo
3 x 2 x 8	80	152	19	4	hole	50	121	19	4	hole
3 x 2 x 10	80	152	19	4	hole	50	121	19	4	hole
4 x 3 x 8	100	191	19	8	hole	80	152	19	4	hole
4 x 3 x 10	100	191	19	8	hole	80	152	19	4	hole
6 x 4 x 10	150	241	20	8	tie rod	100	191	19	8	hole
6 x 4 x 13	150	241	20	8	tie rod	100	191	19	8	hole
8 x 6 x 13	200	298	20	8	tie rod	150	241	22	8	hole
10 x 8 x 15	250	362	20	12	tie rod	200	298	22	8	hole

Dimension in mm

TAB. 3

BASEPLATE

N°	HA	HB	HE	HF	HG	HH	HL	HP		weight (kg)		
245	381	1143	114	1080	95	19	114	32		50		
252	457	1321	152	1257	105	19	114	32		65		
258	533	1473	191	1410	121	25	114	32		85		
264	533	1626	191	1562	121	25	114	32		95		
268	660	1727	241	1664	121	25	114	32		110		
280	660	2032	241	1664	121	25	165	32		125		
368	660	1727	241	1664	121	25	165	32		140		
380	660	2032	241	1969	121	25	165	32		150		
398	660	2489	241	2426	121	25	165	32		190		

Dimension in mm

TAB. 4

MOTOR IP 55 - COUPLING

kW	1,5	2,2	3	4	5,5	7,5	11	15	18,5	22	30	37	45	55	75	90	110	132	160	
Poles	2 4	2 4	2 4	2 4	2 4	2 4	2 4	2 4	2 4	2 4	2 4	2 4	2 4	2 4	2 4	2 4	2 4	2 4	2 4	
frame	90S	90L	90L	100L	112	132S	132S	132M	160M	160L	160M	180L	180M	200L	200L	200L	225M	225M	250M	250M
LM (°)	310	337	337	368	395	437	437	475	655	675	675	768	768	760	760	820	820	820	820	820
Weight kg(°)	13	15	16	23	27	42	43	46	122	121	133	173	173	252	275	301	315	315	315	315
HT	size G3	112	112	112	112	112	117	112	137	117	137	142	142	147	147	147	147	147	147	147
	size G4								137	137	142	142	142	147	147	147	147	147	147	147
L coupling	size G3	100	100	100	100	100	100	100	100	100	100	100	100	100	100	100	100	100	100	100
	size G4								120	120	120	120	120	120	120	120	120	120	120	120
size coupling	A1	A1	A1	A1	A1	A1	A2	A2	A2	A3	A2	A3	A4	A4	A4	A4	A4	A4	A5	A5

Dimensioni in mm / (°) can change for different brands

TAB. 5

SUPPORT: bearing and seal

TAB. 6

CONNECTION LOADS

size	MODEL	Pump side		motor side	
		bearing	seal ring	bearing	seal ring
G3	3 x 2 x 8	NUP310ECJ	50x72x8	5311 E	55x72x8
	3 x 2 x 10				
	4 x 3 x 8				
	4 x 3 x 10				
	6 x 4 x 10				
	6 x 4 x 13				
G4	8 x 6 x 13	6314Z	70x90x10	3314A	70x90x10
	10 x 8 x 15				

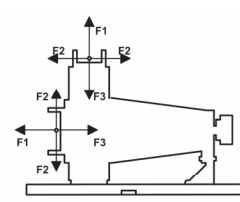

F1 (kg):	250
F2 (kg):	250
F3 (kg):	250
torque (kgm):	28,5

TAB. 7

PUMP PERFORMANCE

MODEL	2 poles						4 poles						6 poles					
	Capacity max (m³/h)		Head Max (m)		Noise (dB)		Capacity max (m³/h)		Head Max (m)		Noise (dB)		Capacity max (m³/h)		Head Max (m)		Noise (dB)	
Frequency	50Hz	60Hz	50Hz	60Hz	50Hz	60Hz	50Hz	60Hz	50Hz	60Hz	50Hz	60Hz	50Hz	60Hz	50Hz	60Hz	50Hz	60Hz
3 x 2 x 8	120	120	50	73	78	80	60	80	12,5	18	74	75						
3 x 2 x 10	140	140	90	130	79	80	80	80	22	32	74	75						
4 x 3 x 8	160	200	52	76	78	79	100	100	13	19	75	77						
4 x 3 x 10	200	240	93	135	78	80	100	120	23	34	74	76						
6 x 4 x 10							250	300	21	31	74	76						
6 x 4 x 13							300	350	36	53	75	76	200	250	17	23	74	75
8 x 6 x 13							700	800	32	47	76	77	500	500	15	20	74	75
10 x 8 x 15							1000	1000	45	66	76	77	700	800	22	29	75	76

temperature support (max): 70 °C

MANUFACTURER DATA



Magnatex Pumps, Inc.
3375 West 12th Street, Houston, TX, 77008
Toll Free: 866.MAG.PUMP
Phone: 713.972.8666
Fax: 713.972.8665

REV.8 - 02/16

CONTRACTUAL DATA	
medium -----	
conc. % -----	temperature °C -----
capacity m ³ /h -----	head m -----

w.o.	

<input type="checkbox"/>	<input type="checkbox"/>
<input type="checkbox"/>	<input type="checkbox"/>

The INSTRUCTION MANUAL must be delivered to the pump-user , who takes diligent note of it, fills in data for Maintenance Department (page 1), keeps the file for subsequent reference.Possible modifications do not imply updating of the existing manuals

© Copyright 2008 - ARGAL srl
Draw and text total or partial duplication is prohibited